

Sentry Smart CDU's™ Power a Cabinet with Four HP BladeSystem® c7000 Enclosures

Server Technology's Sentry Smart CDU™ Solutions to Power a Cabinet with Four HP BladeSystem® c7000 Enclosures

The HP BladeSystem® c7000 10U enclosure supports up to 16 half-height or 8 full-height blades for one of the highest densities in the industry. With an average power usage of 4,458 Watts at peak performance¹ for each BladeSystem, this density poses challenges for power distribution and redundancy. This Application Note will illustrate how to power and provide redundancy for four HP c7000 BladeSystem configurations utilizing Server Technology Sentry CDU's (Cabinet Power Distribution Units).

Configuration for a Four HP BladeSystem c7000 Rack

Each HP BladeSystem fully loaded draws approximately 4458 W, which calculates to a total current draw of 21.43 Amps at 208 V for one system or a total of 85.7 A mps for the four systems. Each BladeSystem contains six single-phase, 208 V C20 power supply inlets which will draw approximately 3.57 Amps each. For this configuration, the ideal setup would be to utilize two rack mounted CDUs with dual input power feeds, Sentry Smart Model CS 12HDY-L30A. Each CDU has two banks of outlets, each with its own input power feed.

Server Technology Products Utilized

- > Two Sentry Smart Model CS-12HDY-L30A CDU (12 outlet, 208 V, 3-phase, 30 A) CDU
- > Power cords: IEC 60320 C20 to C19

Power Requirements for a Cabinet with Four HP BladeSystems

- Total power usage: 17.8 kW (4458 W per HP BladeSystem)
- Total power supply requirements: 208 V, 3-phase, 85.7 Amps
- Input Power Feeds Required: Four 208 V, 3-phase, Wye (Delta available), 30A (each de-rated power feed delivers 8.63 kW of power at 41.5 Amps)
- Number of outlets: 24 IEC 60320 C19 (6 per HP BladeSystem)
- Other requirements: Redundancy, local current indicators to help in load balancing

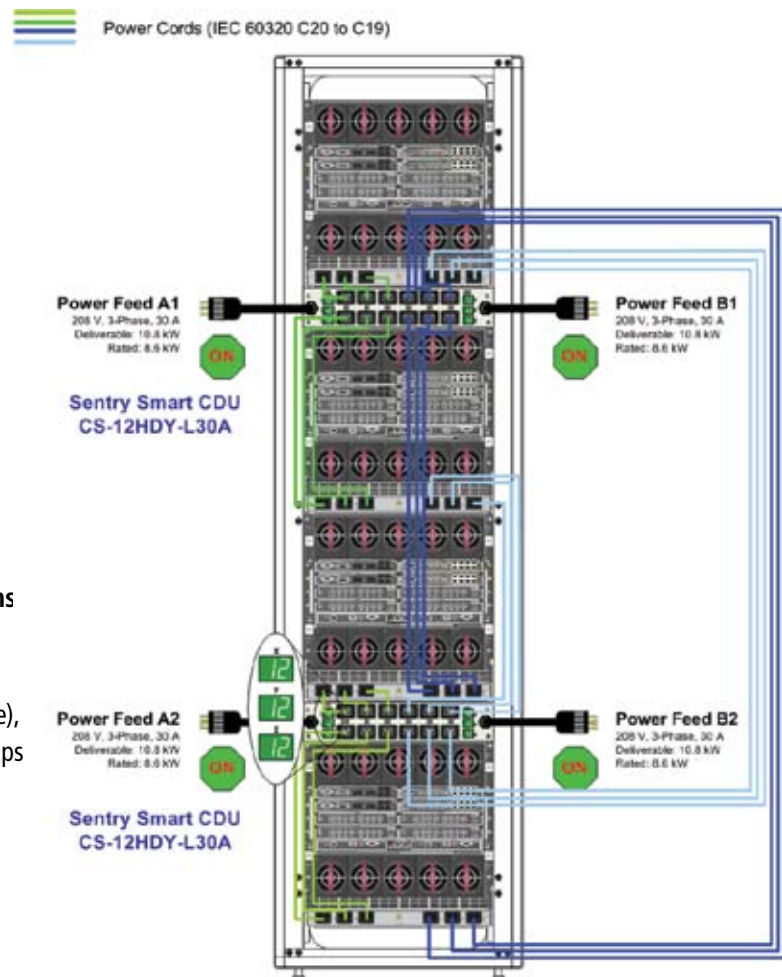

Figure 1: Normal Operation

With both input power feeds live, the system draws 3.5 A per outlet resulting in 12 A per phase circuit

If power is lost on one feed, only one bank of outlets goes out. By using two Sentry CDUs and cross wiring as shown in Fig. 1 and Fig. 2, there is no single point of failure that would result in a loss of a server. **Note:** The power saving features of the c7000 must be turned off for all three outlets on each power supply to equally share the load and to properly balance the 3-phase supply.

Key Benefits

Sentry Smart 30 A CDUs reduce the number units needed to deliver the power required in this cabinet configuration. This in turn reduces the number of power cords needed for each cabinet. Fewer power cords means lower infrastructure costs and improved airflow in a raised floor environment, increasing the cooling efficiencies

Sentry Smart CDUs allows administrators to view the current load and environmental conditions remotely

Three local LEDs – Large, easy-to-read displays let you determine if the load is balanced. Visual indication that power is supplied to the CDU

Environmental measurements – Qty (2) temperature and humidity measurements per CDU (local and remote monitoring)

Local and remote notification if a branch circuit is lost

SNMP Traps / Email Alerts

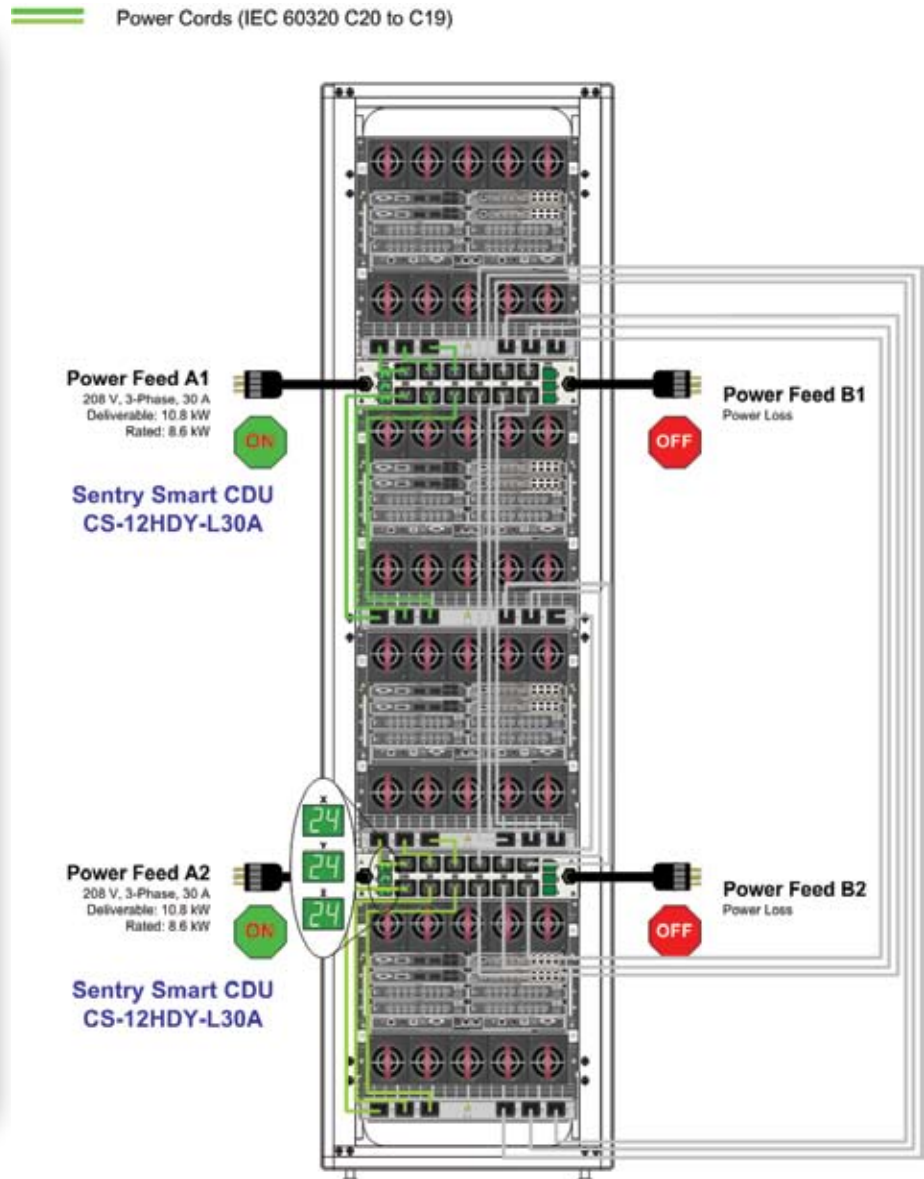

Figure 2: Loss of One Input Power Supply

During the loss of the B input power feeds, the systems will draw all its power from the live supplies. In this situation, the current draw is 7.0 A per outlet and 24 A per phase circuit.

Footnotes:

1. Principled Technologies, Inc. (2007). SPECjbb2005 performance and power consumption on Dell and HP blade servers. Durham, NC. Principled Technologies, Inc.

HP and HP BladeSystem are trademarks or registered trademarks of Hewlett Packard Development Company, L.P.